

CMAK

4th Generation High-Technology Hoists



25 - 35 - 45
70 - 90
Series

Cakmak Crane Inc.
www.cmak.com
sales@cmak.com





Welcome to the Technology

Gathered from the feedbacks of the relatively old design hoists, CMAK's R & D department developed a hoist that is superior and still cost effective. Catch the future with CMK series.



Advantages
Technical Specification
HoistSense
Crane Kits



YouTube



Increased Falls Capability
SMART FALLS SYSTEM

With the compact pulley system, it enables CMK hoists to have higher falls without increasing the size of the hoist.



Maximum Height of Lifting
LARGE DRUM DIAMETER

Compared to the conventional systems, CMK hoists are equipped with a large diameter rope drum, enabling it to have maximum number of reeving for easily reaching high lifting heights.



Maximum Power Economy
REGENERATIVE ENERGY (OPTIONAL)

While lowering, the system feeds back the motors with surplus energy while decreasing the overall consumption of electricity between 25%-40% of crane. CMK hoists are kind to Earth.



Minimum Hook Drift
SHORT DRUM LENGTH

Thanks to the CMK series hoists' design, lifting and lowering is done with minimal hook drift, similar to absolute vertical lifting systems.

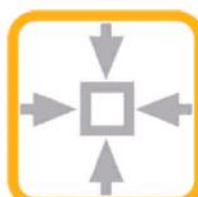

Maximum Reachable Area
COMPACT DESIGN

With smaller and compact design, CMK Hoists can reach more areas for better utilization of working area.



Maximum Wire Rope Service Life
SPECIAL BENDING ANGLE

CMK Hoists' wire rope bending angle is far smaller thus increasing the service life of the wire rope by factor of 4.



Highly Durable and Modular
EASY MAINTENANCE

Every part of the hoist can be easily disassembled and lowering to the ground for effective maintenance and part replacement. CMK Hoist, in terms of mechanical structure and electrical system, are designed with the "plug / remove" principle.



**Long Service Life****HOIST PROTECTION SYSTEM**

CMK series hoists are equipped with PTC, Thermic, Phase Safe-Guard, Emergency System, Double Layer Top and Bottom Limiter and Electro-Mechanical Overload Systems, thus very reliable and safely operational.

**Efficient Main Cooling****HIGHLY EFFICIENT COOLING**

Main lifting motor is located inside of the drum thus benefitting from the air tunnel of the drum with enhancing the cooling operation and keeping the optimum heat level of the motor.

**Minimum Maintenance Requirement****LONG SERVICE LIFE**

CMK series hoist are designed to endure severe conditions for years, also its design lowers the maintenance requirement while reducing your maintenance costs.

**Smooth Acceleration and Deceleration****EASY TO USE**

Thanks to the standard electrical systems of CMK Hoist, hoists operators mistakes (like tipping) is overridden thus ensuring correct operation and minimizing the wear on mechanical parts. CMK Hoists are, as standard, equipped with Inverters which includes cross-travel and lifting / lowering, thus increasing the service life and effective operation.

**Service Optimization****INTELLEGENT MAINTENANCE SUPPORT**

CMK series hoists can be equipped with HoistSense - Electronic Monitoring System, which allows the operators and service crew to optimize the service dates thus minimizes the downtime and maximizes the efficient operation time

**Special Bottom and Top Double Layer Limiter****ACCURATE AND DURABLE LIMITS**

Hook top and bottom travel limits can be easily adjusted, also giving option set limits for slow down and stop for both top and bottom. This will ensure problem-free operation of the users.





Safe Operation
EMERGENCY SYSTEM

In an emergency, users can simply press the emergency stop button, located at the bottom of the pushbutton, to cut the main power of the crane. Also in situation of power surges, CMK hoists will automatically cut the main power to avoid its systems getting damaged.



Operator Health First
LOW CONTROL VOLTAGE

CMK Hoists' standard control voltage is 48V. In case of an insulation problem on the pushbutton, due to a direct damage, only 48V electricity is on the circuits that are close to the operators hand.



Low Operation Noise
HIGH QUALITY OPERATION

In the case of lifting / lowering only noise you're going to hear is the working noise of the fan. Smooth and quiet operation.



Overload Device
SAFE LOAD LIMITER

CMK Hoists' electro-mechanical overload device is very reliable and can easily adjusted with just an allen wrench thus ensure safe operation.



Durable Rope Guide
ROPE GUIDE

CMK series rope guide ensures the wire rope to tightly rolled to the drum and it's design minimises the breakage due to it's flexibility.



High Efficiency
HIGHLY EFFICIENT LIFTING MOTOR

CMK series hoists are capable of operating under heavy conditions with new generation 3000rpm output lifting motors.



Direct Driven Drivers
GTS TYPE TRAVEL MECHANISM

Travel wheels of the hoists are direct driven thus minimises the wear on travel mechanisms.



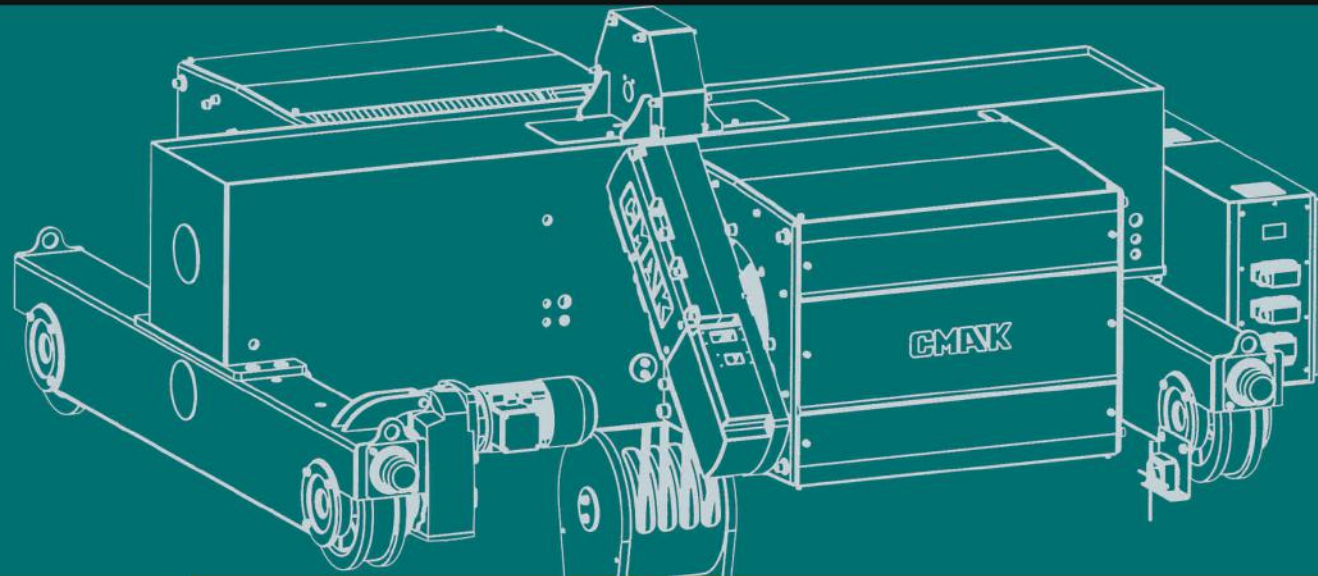

CMK series hoists grant you best return on investment

Up to 80t with vast duty and speed variations depending on your choice

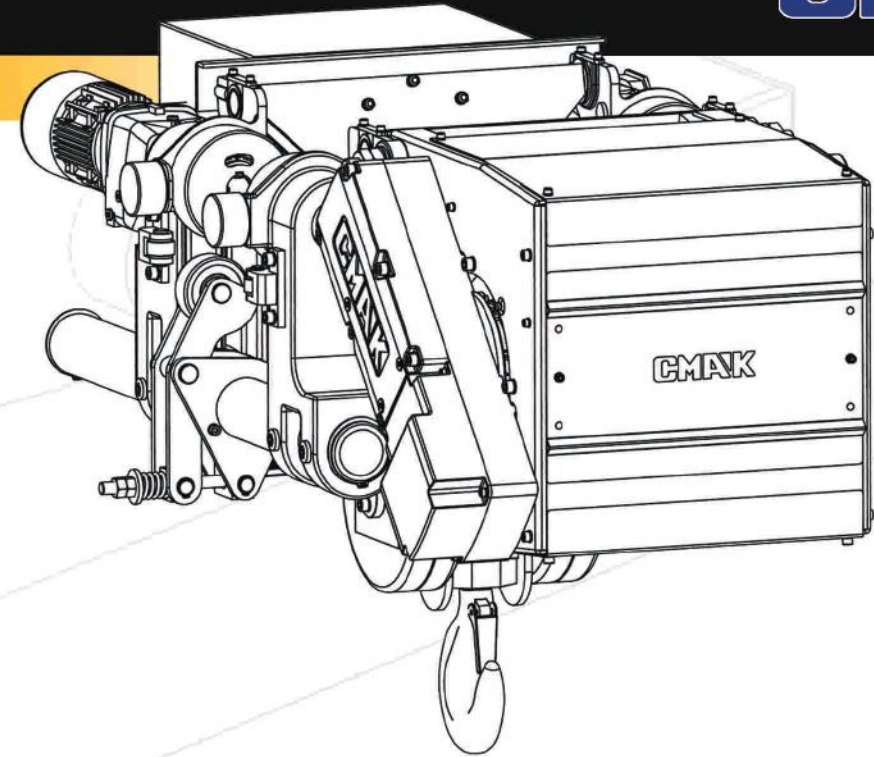
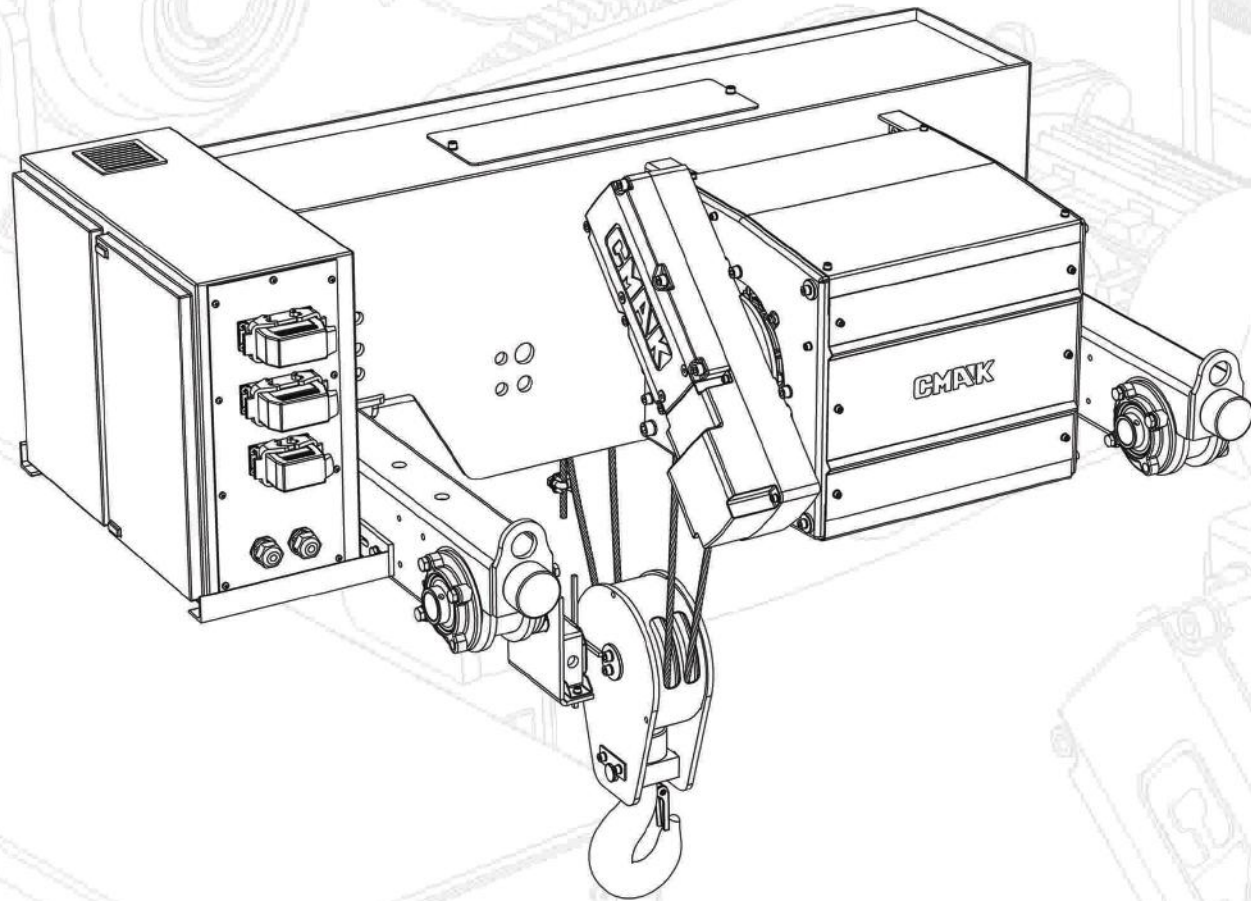

Capacity Kg	Height of Lift m	Hoisting Speed			Cross-Travel Speed			FEM	ISO	Type	Hoist Type				
		Slow m/min	Fast m/min	Ultraspeed m/min	Slow m/min	Fast m/min	Ultraspeed m/min				(S)	(ML)	(MN)	(DY)	True Vertical Lift
1000	33	3,3	20	30	4	16	24	3m	M6	CMK25MXS.011	●	○	○	●	○
	53									CMK25MXA.011	●	○	○	●	○
	73									CMK25MXB.011	●	○	○	●	○
	89									CMK25MXC.011	●	○	○	●	○
	94									CMK25MXC.011	●	○	○	●	○
1250	33	3,3	20	30	4	16	24	2m	M5	CMK25MXS.011	●	○	○	●	○
	53									CMK25MXA.011	●	○	○	●	○
	73									CMK25MXB.011	●	○	○	●	○
	89									CMK25MXC.011	●	○	○	●	○
	94									CMK25MXC.011	●	○	○	●	○
1500	33	3,3	20	30	4	16	24	1Am	M4	CMK25MXS.011	●	○	○	●	○
	53									CMK25MXA.011	●	○	○	●	○
	73									CMK25MXB.011	●	○	○	●	○
	89									CMK25MXC.011	●	○	○	●	○
	94									CMK25MXC.011	●	○	○	●	○
2000	16,5	1,8	10	15	4	16	24	3m	M6	CMK25MXS.021	●	●	○	●	○
	26,5									CMK25MXA.021	●	●	○	●	○
	36,5									CMK25MXB.021	●	●	○	●	○
	47									CMK25MXC.021	●	●	○	●	○
	31,4									CMK35MZS.011	●	○	○	●	○
	50,5	CMK35MZA.011	●	○	○	●	○								
	70,6	CMK35MZA.011	●	○	○	●	○								
	89,6	CMK35MZA.011	●	○	○	●	○								
	89,6	CMK35MZA.011	●	○	○	●	○								
	89,6	CMK35MZA.011	●	○	○	●	○								

Capacity Kg	Height of Lift m	Hoisting Speed			Cross-Travel Speed			FEM	ISO	Type	Hoist Type				
		Slow m/min	Fast m/min	Ultraspeed m/min	Slow m/min	Fast m/min	Ultraspeed m/min				(S)	(ML)	(MN)	(DY)	True Vertical Lift
2500	16,5	1,8	10	15	4	16	24	2m	M5	CMK25MXS.021	●	●	○	●	○
	26,5									CMK25MXA.021	●	●	○	●	○
	36,5									CMK25MXB.021	●	●	○	●	○
	47									CMK25MXC.021	●	●	○	●	○
	31,4									CMK35MZS.011	●	○	○	●	○
	50,5	CMK35MZA.011	●	○	○	●	○								
	70,6	CMK35MZA.011	●	○	○	●	○								
	89,6	CMK35MZA.011	●	○	○	●	○								
	89,6	CMK35MZA.011	●	○	○	●	○								
	89,6	CMK35MZA.011	●	○	○	●	○								
3000	16,5	1,8	10	15	4	16	24	1Am	M4	CMK25MXS.021	●	●	○	●	○
	26,5									CMK25MXA.021	●	●	○	●	○
	36,5									CMK25MXB.021	●	●	○	●	○
	47									CMK25MXC.021	●	●	○	●	○
	31,4									CMK35MZS.011	●	○	○	●	○
	50,5	CMK35MZA.011	●	○	○	●	○								
	70,6	CMK35MZA.011	●	○	○	●	○								
	89,6	CMK35MZA.011	●	○	○	●	○								
	89,6	CMK35MZA.011	●	○	○	●	○								
	89,6	CMK35MZA.011	●	○	○	●	○								
3200	30,4	2,7	16	24	4	16	24	3m	M6	CMK45MXS.011	●	○	○	●	○
	51,2									CMK45MXA.011	●	○	○	●	○
	68,4									CMK45MXB.011	●	○	○	●	○
	87,4									CMK45MXC.011	●	○	○	●	○
	87,4									CMK45MXC.011	●	○	○	●	○
4000	8,2	0,9	5	7,5	4	16	24	3m	M6	CMK25MXS.041	●	●	○	●	○
	13,2									CMK25MXA.041	●	●	○	●	○
	18,2									CMK25MXB.041	●	●	○	●	○
	23,5									CMK25MXC.041	●	●	○	●	○
	15,7									CMK35MZS.021	●	●	○	●	○
	25,2	CMK35MZA.021	●	●	○	●	○								
	35,3	CMK35MZA.021	●	●	○	●	○								
	44,8	CMK35MZA.021	●	●	○	●	○								
	44,8	CMK35MZA.021	●	●	○	●	○								
	44,8	CMK35MZA.021	●	●	○	●	○								
4000	30,4	2,7	16	24	4	16	24	2m	M5	CMK45MXS.011	●	○	○	●	○
	51,2									CMK45MXA.011	●	○	○	●	○
	68,4									CMK45MXB.011	●	○	○	●	○
	87,4									CMK45MXC.011	●	○	○	●	○
	87,4									CMK45MXC.011	●	○	○	●	○

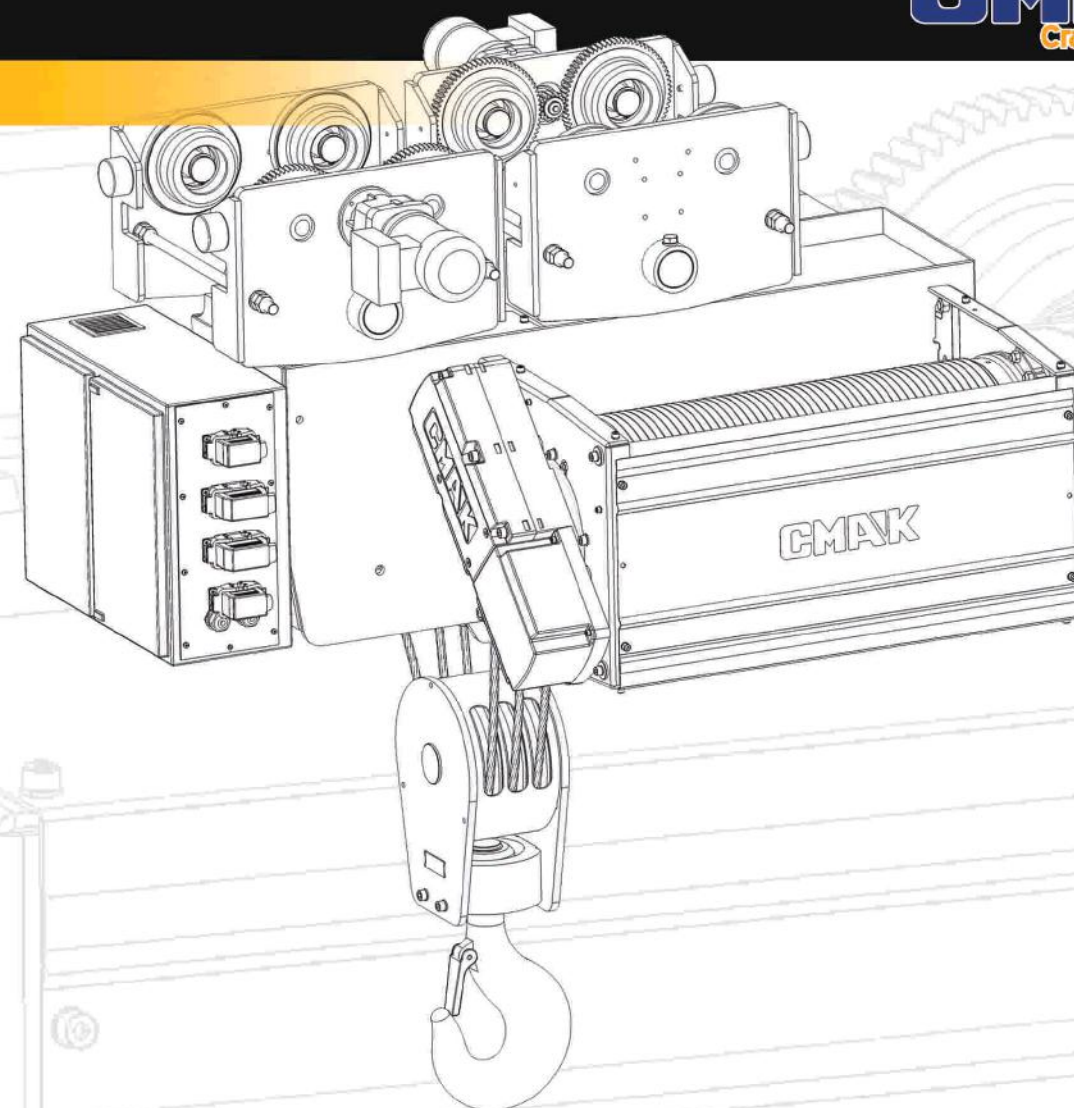
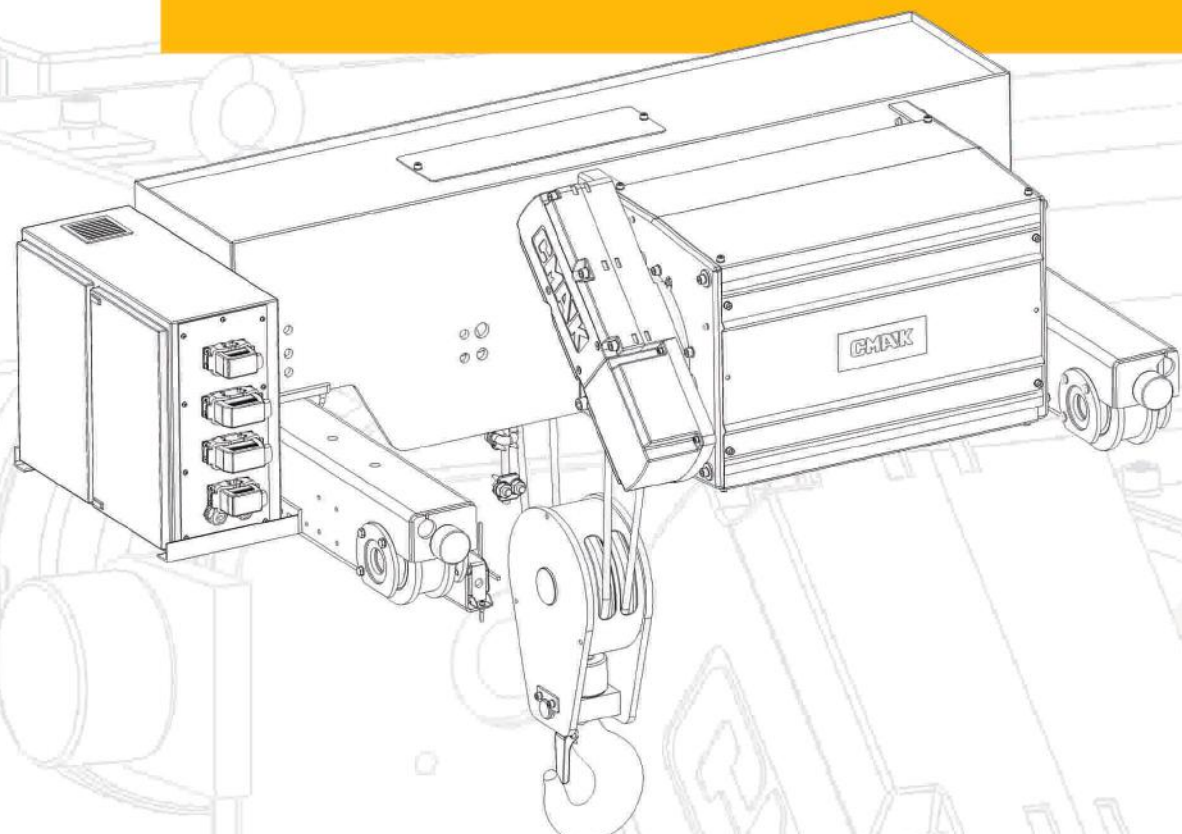

Capacity	Height of Lift	Hoisting Speed			Cross-Travel Speed			FEM	ISO	Type	Hoist Type				
		Slow m/min	Fast m/min	Ultraspeed m/min	Slow m/min	Fast m/min	Ultraspeed m/min				(S)	(ML)	(MN)	(DY)	True Vertical Lift
5000	8,2	0,9	5	7,5	4	16	24	2m	M5	CMK25MXS.041	●	●	○	●	○
	13,2									CMK25MXA.041	●	●	○	●	○
	18,2									CMK25MXB.041	●	●	○	●	○
	23,5	CMK25MXC.041	●	●	○	●	○								
	15,7	CMK35MZS.021	●	●	○	●	○								
	25,2	CMK35MZA.021	●	●	○	●	○								
	35,3	CMK35MZA.021	●	●	○	●	○								
	44,8	CMK35MZA.021	●	●	○	●	○								
	30,4	CMK45MXS.011	●	○	○	●	○								
	51,2	CMK45MXA.011	●	○	○	●	○								
68,4	CMK45MXB.011	●	○	○	●	○									
87,4	CMK45MXC.011	●	○	○	●	○									
6000	8,2	0,9	5	7,5	4	16	24	1Am	M4	CMK25MXS.041	●	●	○	●	○
	13,2									CMK25MXA.041	●	●	○	●	○
	18,2									CMK25MXB.041	●	●	○	●	○
	23,5	CMK25MXC.041	●	●	○	●	○								
	8,8	CMK25OXA.061	●	○	○	●	○								
	12,1	CMK25OXB.061	●	○	○	●	○								
	15,6	CMK25OXC.061	●	○	○	●	○								
	15,7	CMK35MZS.021	●	●	○	●	○								
	25,2	CMK35MZA.021	●	●	○	●	○								
	35,3	CMK35MZA.021	●	●	○	●	○								
44,8	CMK35MZA.021	●	●	○	●	○									
6300	15,2	1,36	8	12	4	16	24	3m	M6	CMK45MXS.021	●	●	○	●	○
	25,6									CMK45MXA.021	●	●	○	●	○
	34,2									CMK45MXB.021	●	●	○	●	○
	43,7									CMK45MXC.021	●	●	○	●	○

Capacity	Height of Lift	Hoisting Speed			Cross-Travel Speed			FEM	ISO	Type	Hoist Type				
		Slow m/min	Fast m/min	Ultraspeed m/min	Slow m/min	Fast m/min	Ultraspeed m/min				(S)	(ML)	(MN)	(DY)	True Vertical Lift
7500	8,8	0,52	3,3	5	4	16	24	2m	M5	CMK25OXA.061	●	○	○	●	○
	12,1									CMK25OXB.061	●	○	○	●	○
	15,6									CMK25OXC.061	●	○	○	●	○
8000	9,1	0,4	2,5	3,75	4	16	24	3m	M6	CMK25OXB.081	●	○	○	●	○
	11,7									CMK25OXC.081	●	○	○	●	○
	7,8	0,82	5,1	7,65	4	16	24	3m	M6	CMK35MZS.041	●	●	○	●	○
	12,6									CMK35MZA.041	●	●	○	●	○
	17,6									CMK35MZA.041	●	●	○	●	○
	22,4	CMK35MZA.041	●	●	○	●	○								
	15,2	1,28	8	12	4	16	24	2m	M5	CMK45MXS.021	●	●	○	●	○
	25,6									CMK45MXA.021	●	●	○	●	○
	34,2									CMK45MXB.021	●	●	○	●	○
	43,7									CMK45MXC.021	●	●	○	●	○
15,7	1,76	10,3	15,5	4	16	24	3m	M6	CMK70MXS.042	●	○	○	●	○	
25,2									CMK70MXA.042	●	○	○	●	○	
35,3									CMK70MXB.042	●	○	○	●	○	
44,8									CMK70MXC.042	●	○	○	●	○	
9000	8,8	0,52	3,3	5	4	16	24	1Am	M4	CMK25OXA.061	●	○	○	●	○
	12,1									CMK25OXB.061	●	○	○	●	○
	15,6									CMK25OXC.061	●	○	○	●	○

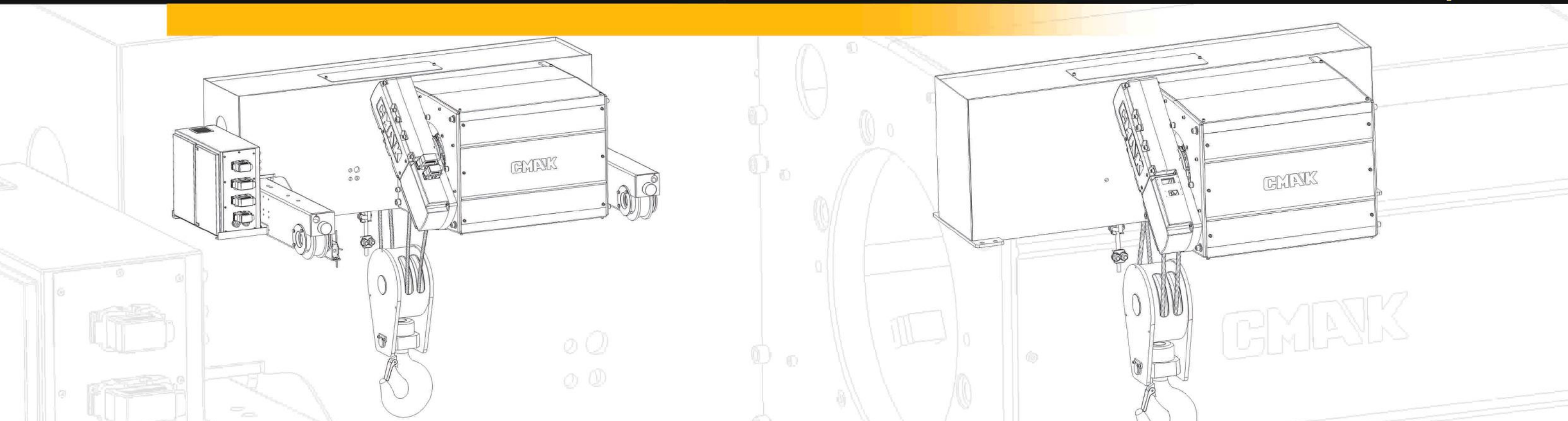

Capacity Kg	Height of Lift m	Hoisting Speed			Cross-Travel Speed			FEM	ISO	Type	Hoist Type				
		Slow m/min	Fast m/min	Ultraspeed m/min	Slow m/min	Fast m/min	Ultraspeed m/min				(S)	(ML)	(MN)	(DY)	True Vertical Lift
10000	9,1	0,4	2,5	3,75	4	16	24	2m	M5	CMK25OXB.081	●	○	●	●	○
	11,7									CMK25OXC.081	●	○	●	●	○
	7,8	0,82	5,1	7,65	4	16	24	2m	M5	CMK35MZA.041	●	●	○	●	○
	12,6									CMK35MZA.041	●	●	○	●	○
	17,6									CMK35MZA.041	●	●	○	●	○
	22,4									CMK35MZA.041	●	●	○	●	○
	22,4									CMK35MZA.041	●	●	○	●	○
	15,2	1,28	8	12	4	16	24	1Am	M4	CMK45MXS.021	●	●	○	●	○
	25,6									CMK45MXA.021	●	●	○	●	○
	34,2									CMK45MXB.021	●	●	○	●	○
	43,7									CMK45MXC.021	●	●	○	●	○
	43,7									CMK45MXC.021	●	●	○	●	○
	15,7	1,76	10,3	15,5	4	16	24	2m	M5	CMK70MXS.042	●	○	○	●	●
	25,2									CMK70MXA.042	●	○	○	●	●
35,3	CMK70MXB.042									●	○	○	●	●	
44,4	CMK70MXC.042									●	○	○	●	●	
44,4	CMK70MXC.042									●	○	○	●	●	
12000	9,1	0,4	2,5	3,75	4	16	24	1Am	M4	CMK25OXB.081	●	○	●	●	○
	11,7									CMK25OXC.081	●	○	●	●	○
	7,8	0,82	5,1	7,65	4	16	24	1Am	M4	CMK35MZA.041	●	●	○	●	○
	12,6									CMK35MZA.041	●	●	○	●	○
	17,6									CMK35MZA.041	●	●	○	●	○
	22,4									CMK35MZA.041	●	●	○	●	○
	22,4									CMK35MZA.041	●	●	○	●	○
	8,4	0,55	3,4	5,1	4	16	24	3m	M6	CMK35OZA.061	●	○	○	●	○
	11,7									CMK35OZB.061	●	○	○	●	○
	14,9									CMK35OZC.061	●	○	○	●	○
	15,7									CMK70MXS.042	●	○	○	●	●
	15,7									CMK70MXS.042	●	○	○	●	●
	25,2	1,76	10,3	15,5	4	16	24	1Am	M4	CMK70MXA.042	●	○	○	●	●
	35,3									CMK70MXB.042	●	○	○	●	●
44,8	CMK70MXC.042									●	○	○	●	●	
44,8	CMK70MXC.042									●	○	○	●	●	
44,8	CMK70MXC.042									●	○	○	●	●	

Capacity Kg	Height of Lift m	Hoisting Speed			Cross-Travel Speed			FEM	ISO	Type	Hoist Type				
		Slow m/min	Fast m/min	Ultraspeed m/min	Slow m/min	Fast m/min	Ultraspeed m/min				(S)	(ML)	(MN)	(DY)	True Vertical Lift
12500	7,5	0,64	4	6	4	16	24	3m	M6	CMK45MXS.041	●	●	○	●	○
	12,8									CMK45MXA.041	●	●	○	●	○
	17									CMK45MXB.041	●	●	○	●	○
	21,8									CMK45MXC.041	●	●	○	●	○
	21,8									CMK45MXC.041	●	●	○	●	○
	15,2	1,28	8	12	4	16	24	3m	M6	CMK90MXS.042	●	○	○	●	●
	25,6									CMK90MXA.042	●	○	○	●	●
	34,2									CMK90MXB.042	●	○	○	●	●
	43,7									CMK90MXC.042	●	○	○	●	●
	43,7									CMK90MXC.042	●	○	○	●	●
15000	8,4	0,55	3,4	5,1	4	16	24	2m	M5	CMK35OZA.061	●	○	○	●	○
	11,7									CMK35OZB.061	●	○	○	●	○
	14,9									CMK35OZC.061	●	○	○	●	○
	14,9									CMK35OZC.061	●	○	○	●	○
16000	8,8	0,42	2,6	3,9	4	16	24	3m	M6	CMK35OZB.081	●	○	○	●	○
	11,2									CMK35OZC.081	●	○	○	●	○
	7,5	0,64	4	6	4	16	24	2m	M5	CMK45MXS.041	●	●	○	●	○
	12,8									CMK45MXA.041	●	●	○	●	○
	17									CMK45MXB.041	●	●	○	●	○
	21,8									CMK45MXC.041	●	●	○	●	○
	21,8									CMK45MXC.041	●	●	○	●	○
	7,8	0,83	5,15	7,73	4	16	24	3m	M6	CMK70MXS.082	●	○	○	●	●
	12,6									CMK70MXA.082	●	○	○	●	●
	17,6									CMK70MXB.082	●	○	○	●	●
	22,4									CMK70MXC.082	●	○	○	●	●
	22,4									CMK70MXC.082	●	○	○	●	●
	15,2	1,28	8	12	4	16	24	2m	M5	CMK90MXS.042	●	○	○	●	●
	25,6									CMK90MXA.042	●	○	○	●	●
34,2	CMK90MXB.042									●	○	○	●	●	
43,7	CMK90MXC.042									●	○	○	●	●	
43,7	CMK90MXC.042									●	○	○	●	●	



Capacity	Height of Lift	Hoisting Speed			Cross-Travel Speed			FEM	ISO	Type	Hoist Type				
		Slow m/min	Fast m/min	Ultraspeed m/min	Slow m/min	Fast m/min	Ultraspeed m/min				(S)	(ML)	(MN)	(DY)	True Vertical Lift
Kg	m														
18000	8,4							1Am	M4	CMK35OZA.061	●	○	●	●	○
	11,7	0,55	3,4	5,1	4	16	24			CMK35OZB.061	●	○	●	●	○
	14,9									CMK35OZC.061	●	○	●	●	○
20000	8,8	0,42	2,6	3,9	4	16	24	2m	M5	CMK35OZB.081	●	○	●	●	○
	11,2									CMK35OZC.081	●	○	●	●	○
	7,5									CMK45MXS.041	●	●	○	●	○
	12,8	0,64	4	6	4	16	24	1Am	M4	CMK45MXA.041	●	●	○	●	○
	17									CMK45MXB.041	●	●	○	●	○
	21,8									CMK45MXC.041	●	●	○	●	○
	8,5	0,44	2,7	4	4	16	24	3m	M6	CMK45OXA.061	●	○	○	●	○
	11,4									CMK45OXB.061	●	○	○	●	○
	14,5									CMK45OXC.061	●	○	○	●	○
7,8	0,83	5,15	7,73	4	16	24	2m	M5	CMK70MXS.082	●	○	○	●	●	
12,6									CMK70MXA.082	●	○	○	●	●	
17,6									CMK70MXB.082	●	○	○	●	●	
22,4	CMK70MXC.082	●	○	○	●	●									
15,2	1,28	8	12	4	16	24	1Am	M4	CMK90MXS.042	●	○	○	●	●	
25,6									CMK90MXA.042	●	○	○	●	●	
34,2									CMK90MXB.042	●	○	○	●	●	
43,7									CMK90MXC.042	●	○	○	●	●	
24000	8,8	0,42	2,6	3,9	4	16	24	1Am	M4	CMK35OZB.081	●	○	●	●	○
	11,2									CMK35OZC.081	●	○	●	●	○
	7,8	0,83	5,15	7,73	4	16	24	1Am	M4	CMK70MXS.082	●	○	○	●	●
	12,6									CMK70MXA.082	●	○	○	●	●
	17,6									CMK70MXB.082	●	○	○	●	●
	22,4									CMK70MXC.082	●	○	○	●	●

Capacity	Height of Lift	Hoisting Speed			Cross-Travel Speed			FEM	ISO	Type	Hoist Type				
		Slow m/min	Fast m/min	Ultraspeed m/min	Slow m/min	Fast m/min	Ultraspeed m/min				(S)	(ML)	(MN)	(DY)	True Vertical Lift
Kg	m														
25000	8,5	0,44	2,7	4	4	16	24	2m	M5	CMK45OXA.061	●	○	○	●	○
	11,4									CMK45OXB.061	●	○	○	●	○
	14,5									CMK45OXC.061	●	○	○	●	○
	8,5	0,3	2	3	4	16	24	3m	M6	CMK45OXB.081	●	○	○	●	○
	10,9									CMK45OXC.081	●	○	○	●	○
	8,4									CMK70OXA.122	●	○	○	●	●
	11,7	0,55	3,4	5,1	4	16	24	3m	M6	CMK70OXB.122	●	○	○	●	●
	14,9									CMK70OXC.122	●	○	○	●	●
	7,5									CMK90MXS.082	●	○	○	●	●
12,8	0,64	4	6	4	16	24	3m	M6	CMK90MXA.082	●	○	○	●	●	
17									CMK90MXB.082	●	○	○	●	●	
21,8									CMK90MXC.082	●	○	○	●	●	
8,5									CMK45OXA.061	●	○	○	●	○	
30000	11,4	0,44	2,7	4	4	16	24	1Am	M4	CMK45OXB.061	●	○	○	●	○
	14,5									CMK45OXC.061	●	○	○	●	○
	8,4									CMK70OXA.122	●	○	○	●	●
	11,7	0,55	3,4	5,1	4	16	24	2m	M5	CMK70OXB.122	●	○	○	●	●
	14,9									CMK70OXC.122	●	○	○	●	●
	8,5									0,3	2	3	4	16	24
10,9	CMK45OXC.081	●	○	○	●	○									
8,4	CMK70OXA.122	●	○	○	●	●									
32000	11,7	0,55	3,4	5,1	4	16	24	1Am	M4	CMK70OXB.122	●	○	○	●	●
	14,9									CMK70OXC.122	●	○	○	●	●
	6,3									CMK70OXA.162	●	○	○	●	●
	8,8	0,42	2,6	3,9	4	16	24	3m	M6	CMK70OXB.162	●	○	○	●	●
	11,2									CMK70OXC.162	●	○	○	●	●
	7,5									CMK90MXS.082	●	○	○	●	●
	12,8	0,64	4	6	4	16	24	2m	M5	CMK90MXA.082	●	○	○	●	●
	17									CMK90MXB.082	●	○	○	●	●
	21,8									CMK90MXC.082	●	○	○	●	●

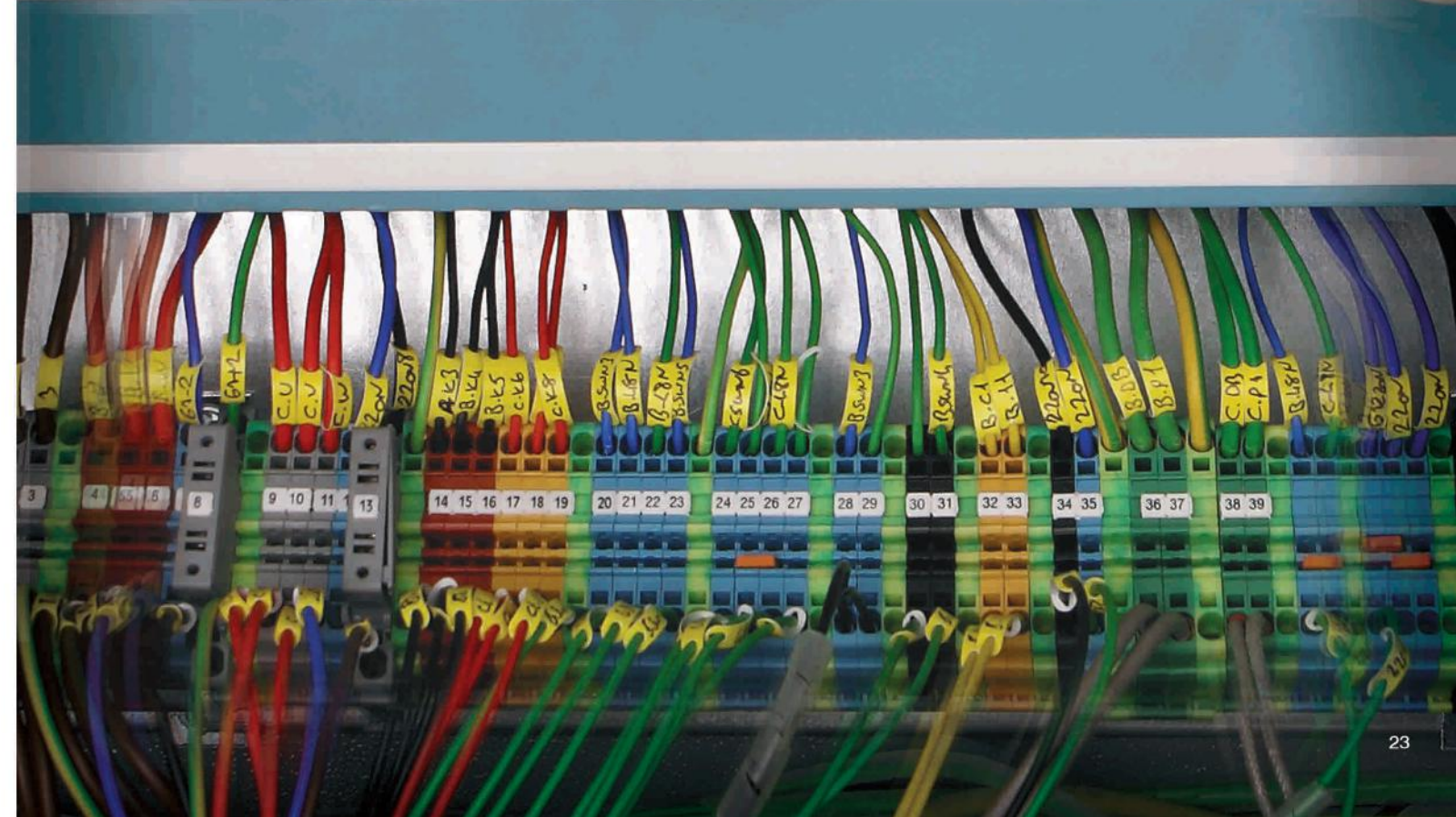
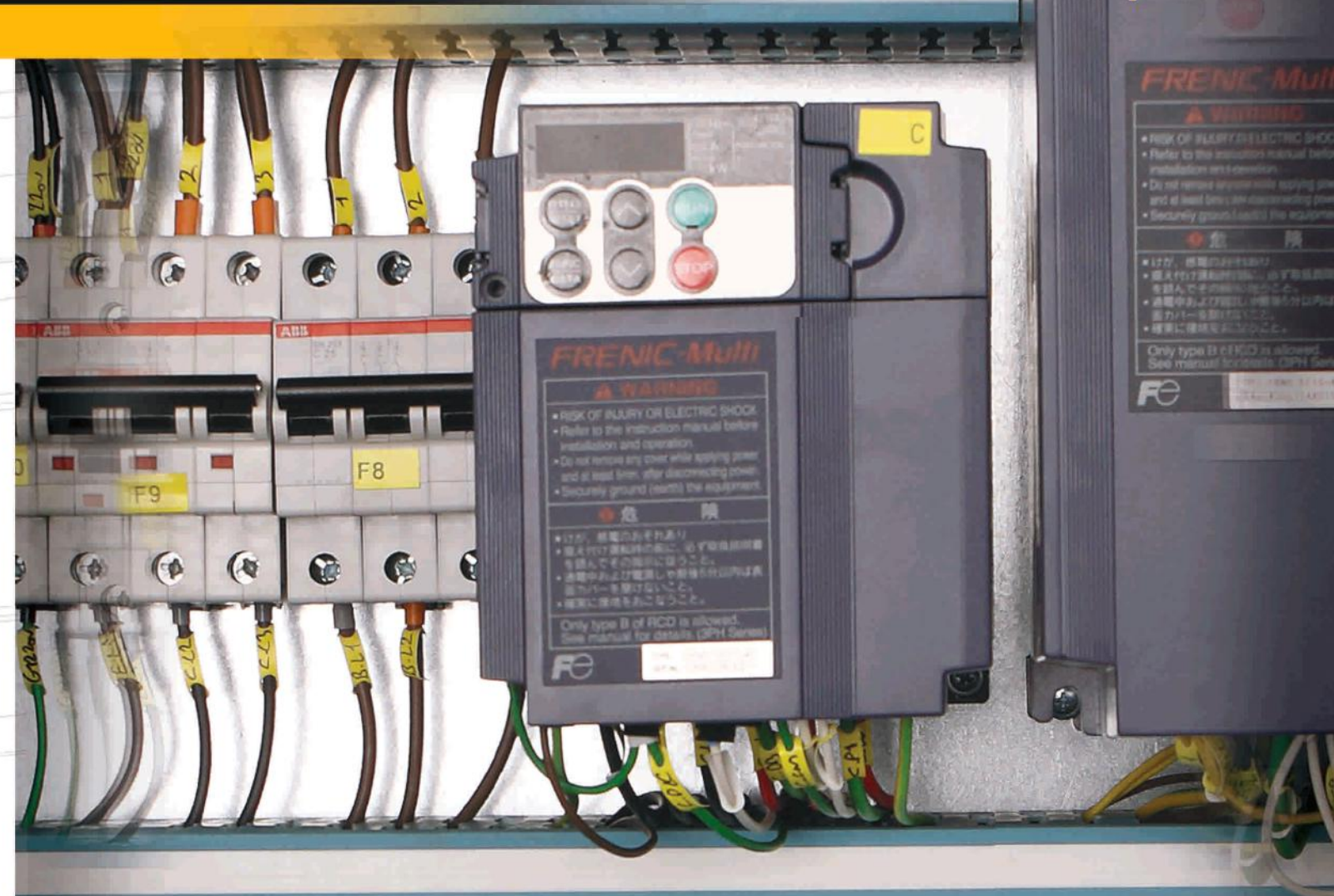
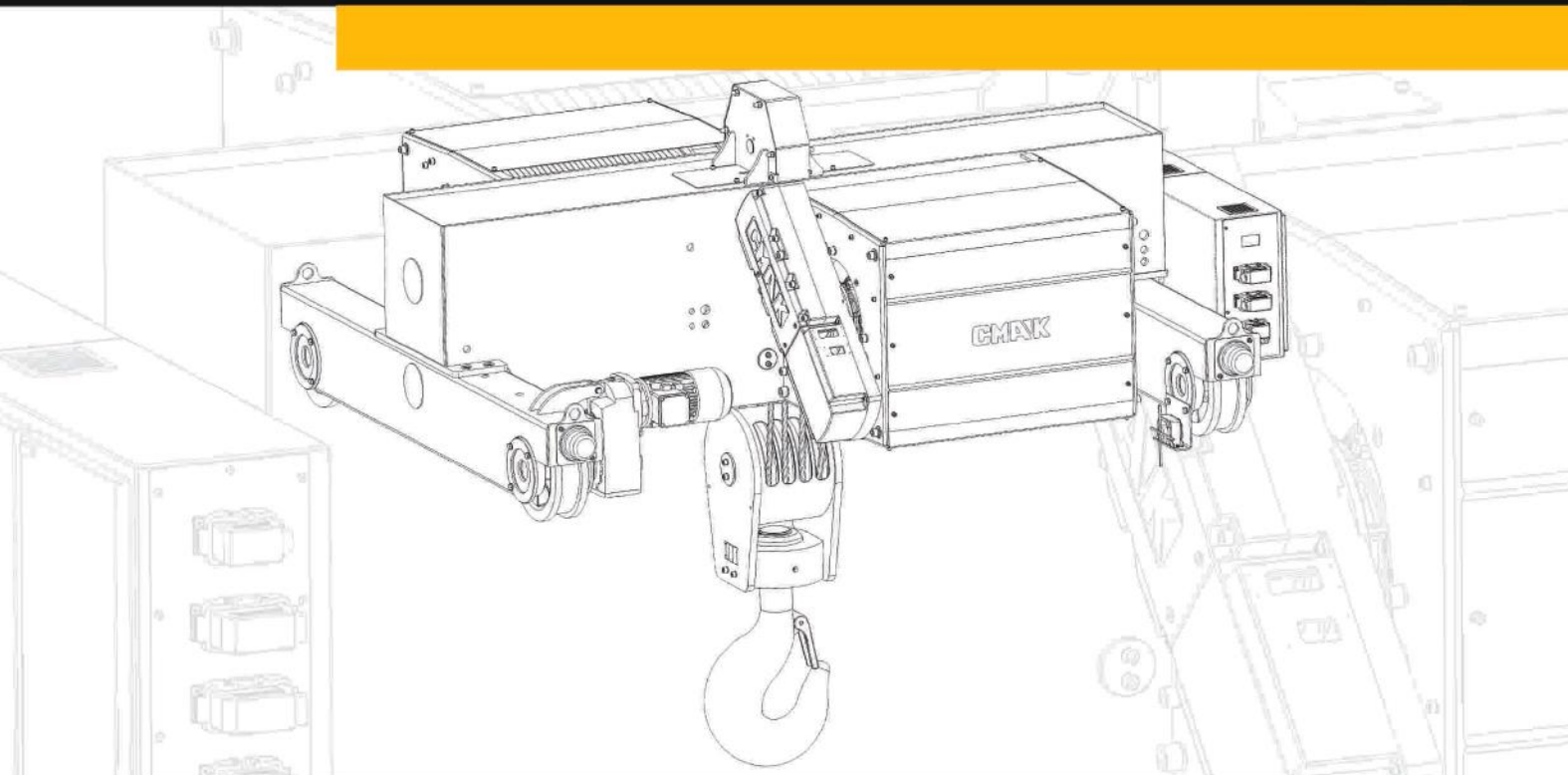

Capacity	Height of Lift	Hoisting Speed			Cross-Travel Speed			FEM	ISO	Type	Hoist Type					
		Slow	Fast	UltraSpeed	Slow	Fast	UltraSpeed				(S)	(ML)	(MN)	(DY)	True Vertical Lift	
Kg	m	m/min	m/min	m/min	m/min	m/min	m/min									
37500	8,5										●	○	○	●	●	
	11,4	0,44	2,67	4	4	16	24	3m	M6	CMK90OXA.122	●	○	○	●	●	
	14,5									CMK90OXB.122	●	○	○	●	●	
40000	8,5										●	○	○	●	○	
	10,9	0,3	2	3	4	16	24	1Am	M4	CMK45OXB.081	●	○	○	●	○	
	6,3									CMK45OXC.081	●	○	○	●	○	
	8,5									CMK70OXA.162	●	○	○	●	●	
	8,8	0,42	2,6	3,9	4	16	24	2m	M5	CMK70OXB.162	●	○	○	●	●	
	11,2									CMK70OXC.162	●	○	○	●	●	
	7,5									CMK90MXS.082	●	○	○	●	●	
	12,8	0,64	4	6	4	16	24	1Am	M4	CMK90MXA.082	●	○	○	●	●	
	17									CMK90MXB.082	●	○	○	●	●	
21,8									CMK90MXC.082	●	○	○	●	●		
48000	6,3										●	○	○	●	●	
	8,8	0,42	2,6	3,9	4	16	24	1Am	M4	CMK70OXA.162	●	○	○	●	●	
	11,2									CMK70OXB.162	●	○	○	●	●	
50000	8,5										●	○	○	●	●	
	11,4	0,44	2,67	4	4	16	24	2m	M5	CMK90OXA.122	●	○	○	●	●	
	14,5									CMK90OXB.122	●	○	○	●	●	
	6,4									CMK90OXC.122	●	○	○	●	●	
60000	8,5	0,3	2	3	4	16	24	3m	M6	CMK90OXA.162	●	○	○	●	●	
	10,9									CMK90OXB.162	●	○	○	●	●	
	8,5									CMK90OXC.162	●	○	○	●	●	
	11,4	0,44	2,67	4	4	16	24	1Am	M4	CMK90OXA.122	●	○	○	●	●	
63000	6,4										●	○	○	●	●	
	8,5	0,3	2	3	4	16	24	2m	M5	CMK90OXB.122	●	○	○	●	●	
	10,9									CMK90OXC.122	●	○	○	●	●	
80000	6,4										●	○	○	●	●	
	8,5	0,3	2	3	4	16	24	1Am	M4	CMK90OXA.162	●	○	○	●	●	
	10,9									CMK90OXB.162	●	○	○	●	●	

*UltraSpeed for CMK70 & CMK90 electric wire rope hoists and optional for the rest.



CMK SERIES

Double Girder EOT Crane

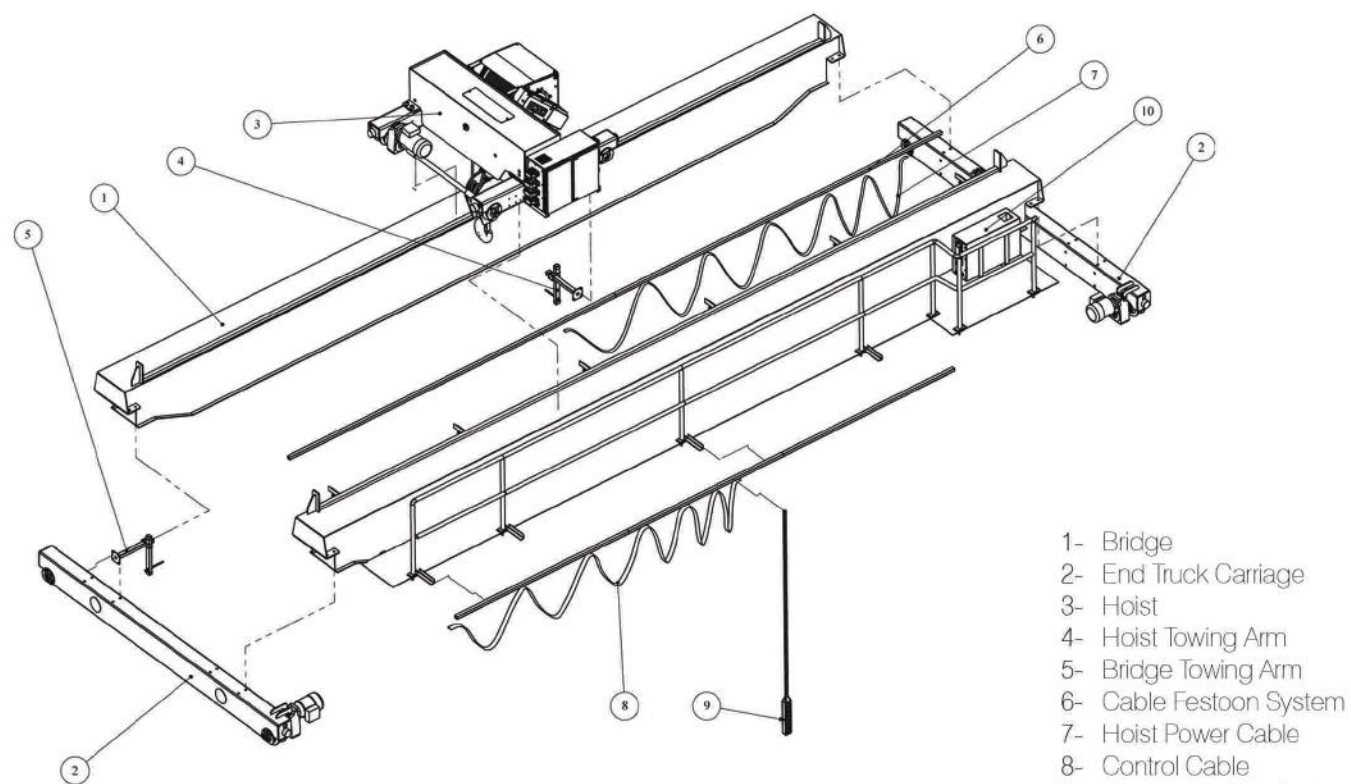

- 1- Bridge
- 2- End Truck Carriage
- 3- Hoist
- 4- Hoist Towing Arm
- 5- Bridge Towing Arm
- 6- Cable Festoon System
- 7- Hoist Power Cable
- 8- Control Cable
- 9- Pushbutton Pendant
- 10- Crane Control Box

Single Girder EOT Crane

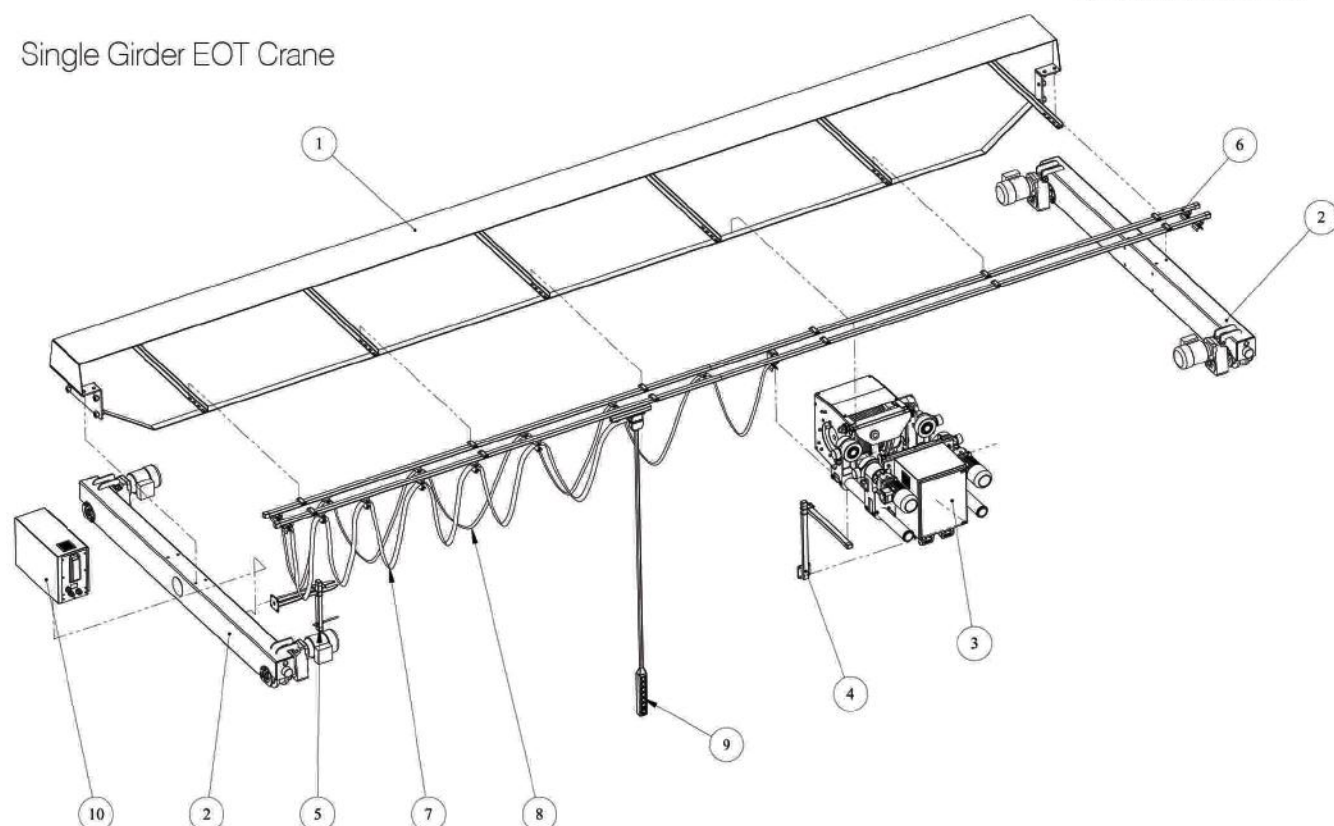

STANDARD FEATURES

- Frequency inverter controlled hoisting (standard 6:1 ratio) and cross-travel drives.
- Higher lifting heights with Compact 8 strand 2160N/mm² galvanized wire rope.
- Very quiet and smooth operation.
- Mechanical structure and electrical systems have modular design with the 'plugs and sockets' principle.
- Thermal protection against overheating in hoisting motor.
- Lifting and lowering actions with minimal hook drift.
- Electromagnetic DC brake with rubber seal.
- Electro-mechanical overload device to avoid damage the machinery, system and building.
- 4 layer rotary limit switch with slow-down/stop functions in upper and lower positions.
- Direct driven cross-travel mechanisms.
- Articulated crab to ensure positive contact of all wheels with rails.
- GGG70 Graphite Cast Iron Rope Guide with higher flexibility and durability.
- Ergonomic and durable Pushbutton with emergency-stop.
- Operating feed: 380-415V @50 Hz / Control voltage: 48V
- Lifting components are covered with high quality Acrylic + Epoxy paint.
- IP55

OPTIONAL FEATURES

- Hoistsense:
 - Real-time monitoring (SWP, remaining duration of service)
 - Increased efficiency with ultraspeed function
 - Weighing display
 - Service optimization
 - Informative Display
- Radio Remote Control.
- Regenerative system: 25-40% power saving
- Transformer + Main Contactor for standalone operability
- Suitability to non-standard feeding voltages.
- Special modifications for hot zone, cold zone, humid zone (from -40 °C to +55 °C.)
- Encoder for Hoisting & Cross-travel.
- Anti-Sway Application
- Anti-Collision Systems.
- Manual Brake Release for Hoisting Drive.
- External Hoisting and Cross-Travel Cooling Fans.
- Non-standard creep/fast speed ratio
- Surface Hardened Wheels
- Marine Paint





Sense[®] Hoist

Electronic Hoist Monitor & Control Unit

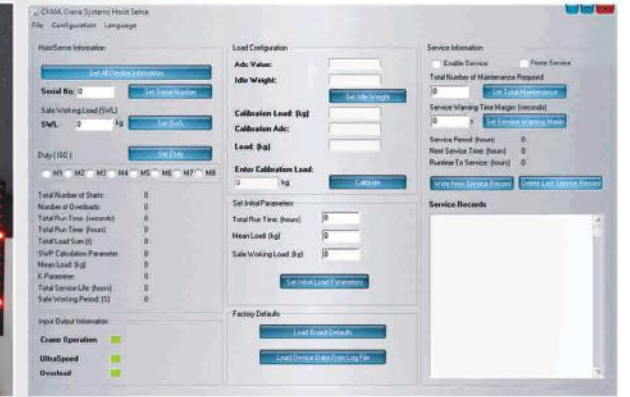
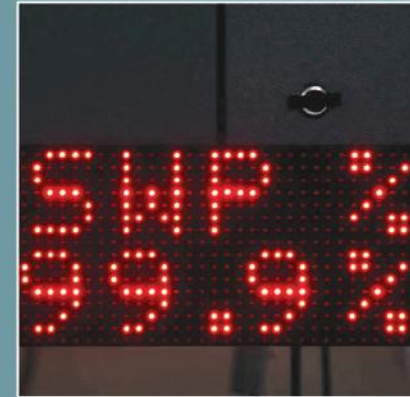

Increase your profitability

HoistSense is an advanced electronic system that constantly keeps track of usage, load and critical incidents; while using these information to the advantage of the user to further increase the efficiency and decrease the downtime of the hoist.

Features

- **Real-Time Monitoring**
 - Permanent SWP (Safe Working Period) calculation.
 - Up-to-date information about the remaining duration of service
 - Comply with the Regulations.
- **Increased Efficiency**
 - With UltraSpeed function enabled, HoistSense increases speed to 150% nominal speed on all motions when the load is below 15% of the SWL (Safe Working Load).
- **Safe Working**
 - Continuous overload protection with precisely calculated strain gauge load measuring system.
- **Weighing Display**
 - Real-time display of the loads via strain gauge sensor
- **Service Optimization**
 - Available Alarms for preventive maintenance periods
 - Tracking of Past Maintenances

Informative Display

- With its display mounted on hoist, the HoistSense informs the operator and maintenance crew for critical information (Total runtime, Number of Overloads, Next Service Hour - Dynamic, Remaining SWP%, Number of Starts, Average Load)
- Comply with the regulations.

Easy to Use

- HoistSense does not add more buttons or require constantly checking the pushbutton pendant, as the system will start displaying the load on the large display attached to the hoist - easily visible- immediately after the operator starts commanding the crane. And the stored information will be shown on the large display after the hoists stays idle for a short period of time.

Stand-alone Application

- Can be integrated to any of your hoists.

Stored Parameters

- Remaining Safe Working Period (SWP) of the hoist
- Current load on the hook
- Total number of overload incident
- Total running time of the hoisting motor
- Mean load
- Load Spectrum (Light, Medium, Heavy, Very Heavy)
- Total number of starts
- Time to next maintenance (depending on the usage - Dynamic)
- Duty

Functions

- Weighing and Informative Display
- Overload Limiter
- Faster speeds depending on the load
- Dynamic Service Timer



End Truck Carriages



Standard Features

- * GGG70 grey cast iron / forged
- * Easily replaceable wheels
- * Zinc enhanced epoxy primer coating
- * Up to 4m wheel base with 4 wheels per crane or bogie type with up to 8 wheels per crane
- * Two flanged wheels
- * Maintenance free bearings
- * Anti-derail
- * Available for top connection, side connection, and top & side connection

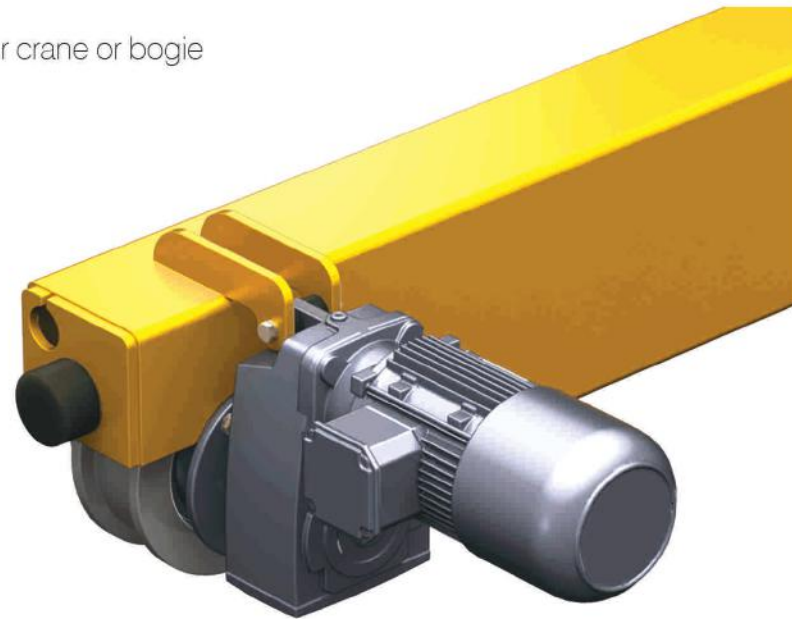

Optional Features

- * Manual parking lever
- * HRC45 surface hardening
- * Rail sweepers and lateral guide rollers

Wheel Diameter	Suitable Standard Rail Width	Standard Wheel Groove	Custom Wheel Groove	Dynamic Wheel Load	Suitable Drive
mm	mm	mm	mm	kgf	
GTS125	40	50	50-110	2670	CD12
GTS160	50	60	50-110	4520	CD12,CK13
GTS200	50	60	50-110	5660	CD12,CD22,CK13,CKG13,CK23
GTS250	50	60	50-110	7640	CD22,CD32,CK13,CKG13,CK23
GTS315	60	70	50-110	11920	CD32,CD42,CD43,CK23,CK33,CK43
GTS400	70	80	50-110	18200	CD32,CD42,CD43,CD52,CD62,CD63,CK33,CK43,CK53
GTS500	70	80	50-110	23430	CD42,CD43,CD52,CD62,CD63,CK43,CK53,CK63,CK73

Wheel loads in accordance with FEM 2m(ISO M5) and 40m/min nominal speed.
Subject to change without prior notice.

Crane Wheel Blocks



Standard Features

- * GGG70 grey cast iron / forged
- * Easily replaceable wheels
- * Zinc enhanced epoxy primer coating
- * Various connection types
- * Two flanged wheels
- * Anti-derail
- * Maintenance free bearings
- * Very modular and flexible for modernizations or new systems

Wheel diameter	Suitable Standard Rail Width	Standard Wheel Groove	Dynamic Wheel Load
mm	mm	mm	kgf
GTS160	50	60	4520
GTS200	50	60	5660
GTS250	50	60	7640
GTS315	60	70	11920
GTS400	70	80	18200

Wheel loads in accordance with FEM 2m(ISO M5) and 40m/min nominal speed.
Subject to change without prior notice.

Optional Features

- * HRC45 surface hardening

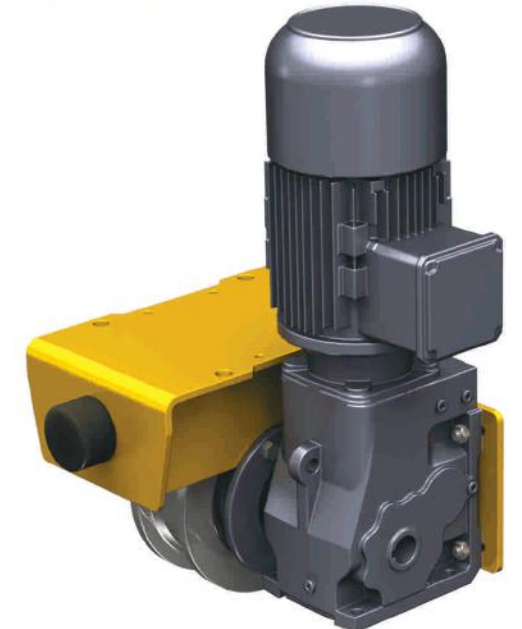
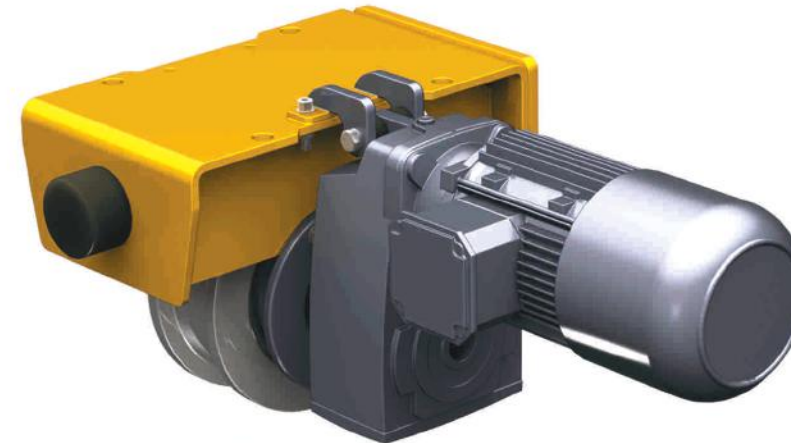

Wheel Rolling Diameter	Code	Description	Groove width	Suitable Drive Types			
mm			mm	CD12	CD22	CD32	CD42
				CK13	CK23	CK33	
160	G.160	GTS160 Wheel Block Non Driven	60				
	G.160T1	GTS160 Wheel Block Driven Ø30	60	X			
200	G.200	GTS200 Wheel Block Non Driven	60				
	G.200T1	GTS200 Wheel Block Driven Ø30	60	X			
	G.200T2	GTS200 Wheel Block Driven Ø35	60		Only CD22		
250	G.250	GTS250 Wheel Block Non Driven	60				
	G.250T1	GTS250 Wheel Block Driven Ø35	60		X		
315	G.315	GTS315 Wheel Block Non Driven	75				
	G.315T1	GTS315 Wheel Block Driven Ø35	75		Only CD22		
	G.315T2	GTS315 Wheel Block Driven Ø40	75			Only CD22	
400	G.400	GTS400 Wheel Block Non Driven	80				
	G.400T1	GTS400 Wheel Block Driven Ø40	80			Only CD22	
	G.400T2	GTS400 Wheel Block Driven Ø50	80				X

* "X" means both options are available
Subject to change without prior notice.